

# Contactless MEMS Tilt Angle Sensor

## MIDORI ESC30xxZ-R



### General

- Dual Axis Tilt Angle Sensor using MEMS Technology
- Effective Electrical Tilt Angle:  $\pm 10^\circ$  (ESC3010Z-R--)
- $\pm 20^\circ$  (ESC3020Z-R--)
- $\pm 30^\circ$  (ESC3030Z-R--)
- $\pm 45^\circ$  (ESC3045Z-R--)
- $\pm 60^\circ$  (ESC3060Z-R--)
- $\pm 80^\circ$  (ESC3080Z-R--)
- Absolut Linearity:  $\pm 0.5\%FS$

- Stable Temperature Characteristic
- Output: Voltage Ratio and Serial RS-485
- High Environmental Performance IP67

### Material

Housing: Aluminum die cast

### Dimension (mm)

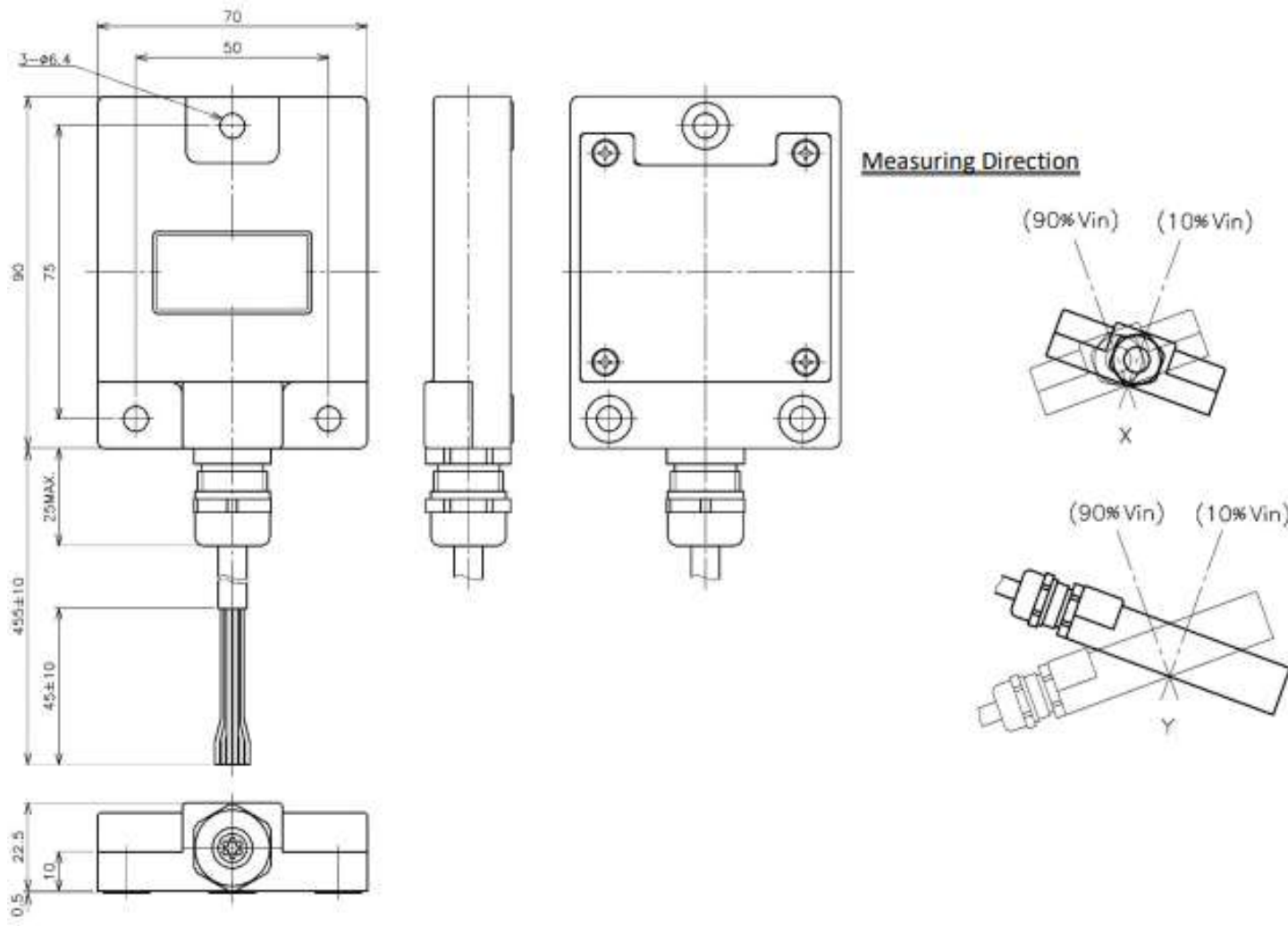

### Output Characteristics

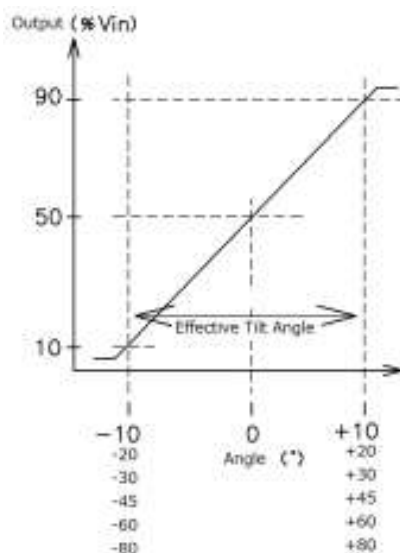

### Schematic

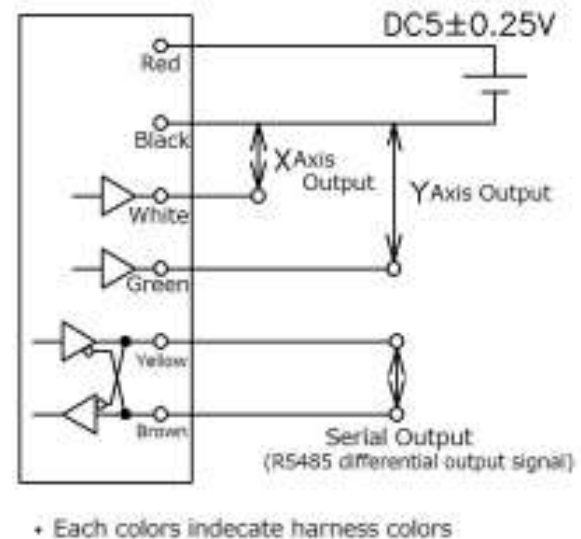

# Specifications

## Electrical Specifications

ESC30xxZ-R		
	Voltage Ratio	Serial RS-485
Effective Electrical Tilt Angle	$\pm 10^\circ$ , $\pm 20^\circ$ , $\pm 30^\circ$ , $\pm 45^\circ$ , $\pm 60^\circ$ , $\pm 80^\circ$	$\pm 80^\circ$
Absolute Linearity	$\pm 0.5\%FS$	$\pm 0.1^\circ$ ( $\sim \pm 10^\circ$ ) $\pm 0.2^\circ$ ( $\sim \pm 30^\circ$ ) $\pm 0.5^\circ$ ( $\sim \pm 80^\circ$ )
Input Voltage	DC5V $\pm$ 0.25V	---
Supply Current	75mA MAX.	---
Output Range	10~90%Vin	---
Digital Damping Control	12bit equivalent <ul style="list-style-type: none"> <li>• Step Response (Time Constant): 443ms (STANDARD)</li> <li>• Selectable time constant during 70ms~900ms in 16 steps (Option)</li> <li>• Digital Damping Control Teach-in Setting is available (Option)</li> </ul>	
Temp. Characteristic	0° Position: $\pm 0.5^\circ$ (-30~+80°C, Reference Temp. +25°C)	
Index Point Setting (Option)	Configurable within 0° $\pm 5^\circ$ range	

## Mechanical Specifications

Weight	Approx. 300g
--------	--------------

## Environmental Specifications

Cable	6 Cores Cabtyre Cable, Dia:Φ7.4mm, Core: 0.5mm2
EMS	10MHz~1GHz • 50V/m (ISO11452-3), Output Error: $\pm 1\%Vin$
EMI	CISPR25 3 <sup>rd</sup> . Edit CLASS1
Operating Temperature	-30~+85°C
ESD	IEC61000-4-2 $\pm 12KV$
Vibration	70m/S2, 5~200Hz, 10min, 2hours
Shock	1000m/S2, Semi Sinusoidal wave 6ms
IP Level	IP 67

## Options

- Effective Tilt Angle: Separate tilt angle setting of X and Y axis

## Special Functions

### 1. Index Point Resetting Function --- Reconfiguring the horizontal position

ESC30xxZ can be reset to a level position ( $\pm 0^\circ$  horizontal position) in the following 2 ways:

#### ① User-Configurable Adjustment Card\* \*Sold separately

Cancel or reset to a level position (0° horizontal position) easily by using the User-Configurable Adjustment Card.

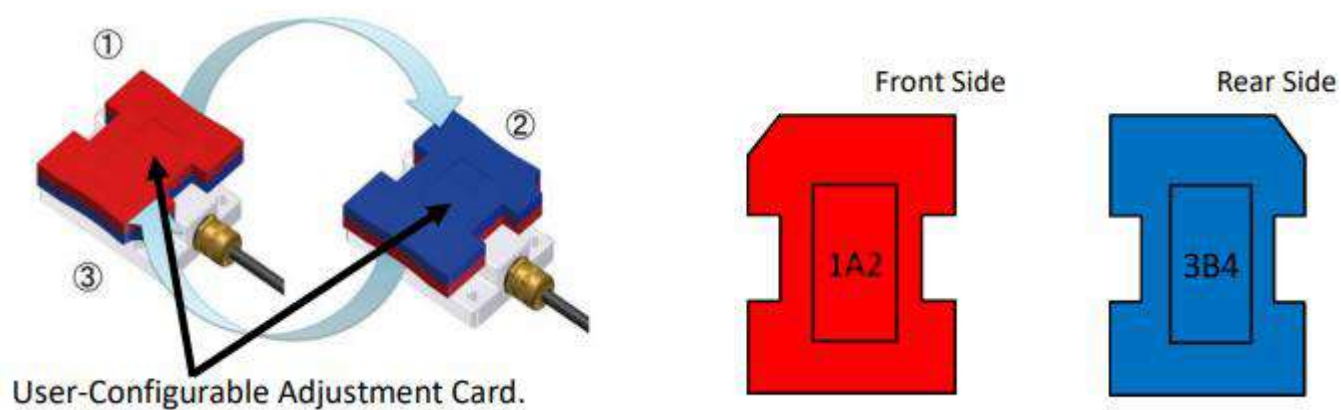

Placing the adjustment card for 1sec on the ESC30xxZ in the following manner resets or cancels the level position.

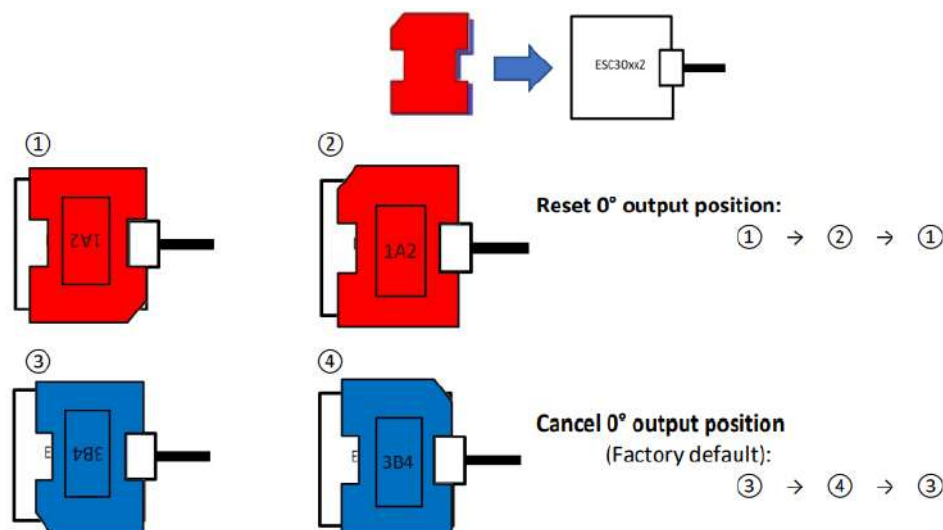

## ② Using the RS-485 communication protocol

The index point can also be configured manually by using the RS-485 protocol.  
(Refer to **3. Serial Communication Function**, Section **8. Reset Index Point** on page 5)

## 2. Programmable Digital Damping Control Function

The ESC30xxZ can apply a digital filter that removes external noise. You can select from 16 available settings (Refer to **3. Serial Communication Function**, Section **7. Reset Digital Damping Control** on page 4)

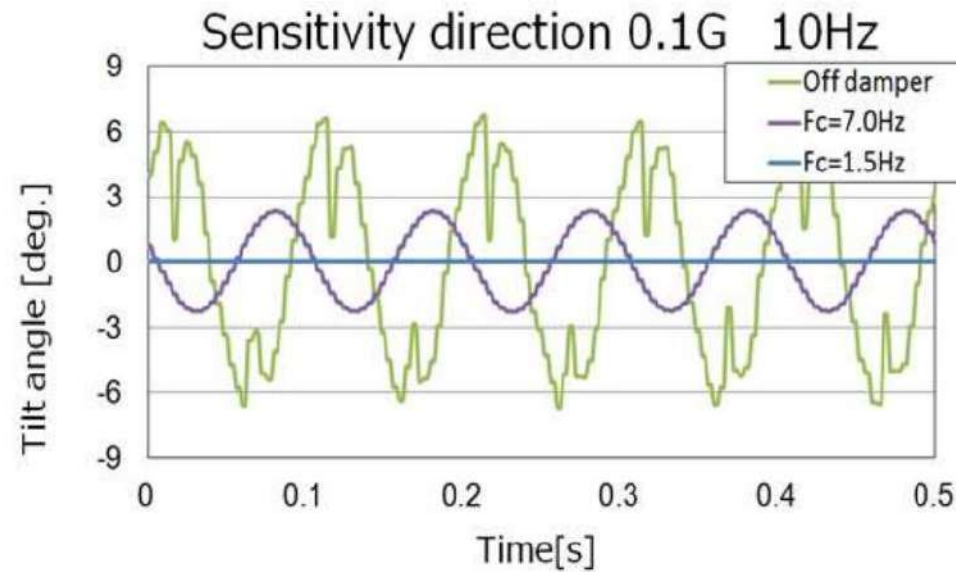

## 3. Serial Communication Function

The ESC30xxZ has a RS-485 as a serial interface.

Interface	RS-485 2 wires Master (Controller) ID: 0 Slave (Sensor) ID: 0001~9998 (9999: Broadcast) Up to 32 slaves can be multi-dropped to the same network cable.
Communication Speed	9600bps (default) or 115200bps
Format	Start bit: 1 bit Data: 8 bits Stop bit: 1 bit No Parity bit

### Command Frame

DUMMY	'<'	ID	Space	Command	Space	Data	'>'	CRC	CR
0x2a	0x3c		0x20	(1~)	0x20	(1~)	0x3e	(4)	0x0d
(1)	(1)	(4)	(1)		(1)		(1)		(1)

### Response Frame

DUMMY	'['	ID	Space	Command	Space	Data	Error Code	']'	CRC	CR
0x2a	0x5b		0x20	(1~)	0x20	(1~)	(3)	0x5d	(4)	0x0d
(1)	(1)	(4)	(1)		(1)			(1)		(1)

### CRC

Using CRC instead of Parity.

The calculation object of the CRC is from ID to the data end.

### CCIT CRC16

Bit length	16bit
Polynomial	$1+X^5+X^{12}+x^{16}$
Initial Value	0xFFFF
Feed	LSB First (right-feed)
Output operation	No output inverting

### Error code

R00	No error
R01	Wrong command
R07	Violating value

## Serial Command Functions

The following functions are available by serial commands:

### 1. Acquiring and Changing ID

Command Frame	<0001 ID 0032>
Response Frame	[0001 ID 0032 R00]
Data Value	0001 ~ 9999 Default: '0001'
Function	Change ID

## 2. Acquiring Serial Number

Command Frame	<0001 SERIAL>
Response Frame	[0001 SERIAL 123456789 R00]
Data Value	000000001 ~ 999999999
Function	Acquiring serial number

## 3. Acquiring Tilt Angle Data (Single Incidence)

Command Frame	<0001 A>
Response Frame	[0001 A "X" "Y" R00]
Data Value	"X" : X axis tilt angle data "Y" : Y axis tilt angle data -999.99 ~ 999.99 (deg.)
Function	Acquiring tilt angle data only once from ESC

## 4. Serially Acquiring Tilt Angle Data (Begin)

Command Frame	<0001 A_START>
Response Frame	[0001 A "X" "Y" R00]
Data Value	"X" : X axis tilt angle data "Y" : Y axis tilt angle data -999.99 ~ 999.99 (deg.)
Function	Start acquiring tilt angle data serially

## 5. Serially Acquiring Tilt Angle Data (End)

Command Frame	<0001 STOP>
Response Frame	[0001 STOP R00]
Function	Stop acquiring tilt angle data

## 6. Setting Output Cycle of Serial Data

If data is not attached to the command frame, the response frame will be the current setting value.

Command Frame	<0001 INTERVAL 200>
Response Frame	[0001 INTERVAL 200 R00]
Data Value	100 ~ 10000, Step Default: '200' (ms)
Function	Setting output cycle of serial data

## 7. Resetting Digital Damping Control

If data is not attached to the command frame, the response frame will be the current setting value.

Command Frame	<0001 DAMPER 01>
Response Frame	[0001 DAMPER 01 R00]
Data Value	00 ~ 15 Default: 00
Function	Reset digital damping level

## Digital Damping Control Setting Value and Cut-off Frequency

Digital Damping Level	Cut-off Frequency [Hz]	Time Constant [ms]	Figures (Model #)
00	11.22	60	D0
01	9.27	114	D1
02	7.65	126	D2
03	6.32	140	D3
04	5.21	156	D4
05	4.3	181	D5
06	3.55	205	D6
07	2.93	246	D7
08	2.42	277	D8
09	2.00	321	D9
10	1.65	378	DA
11	1.36	443	DB (STD)
12	1.12	532	DC
13	0.92	627	DD
14	0.76	749	DE
15	0.62	900	DF

## 8. Resetting the Index Point

Command Frame	<0001 INDEX_SET>
Response Frame	[0001 INDEX_SET "X" "Y" R00]
Data Value	"X" : X axis Index Point "Y" : Y axis Index Point -5.000 ~ +5.000 Default : '0.0' (deg.)
Function	Reset index position (horizontal level) $\pm 0^\circ$ Available reset range $\pm 5^\circ$

## 9. Initializing the Setting

Command Frame	<0001 RESTORE>
Response Frame	[0001 RESTORE R00]
Function	Initialize ESC30xx prior to shipping

## Model Number Designation

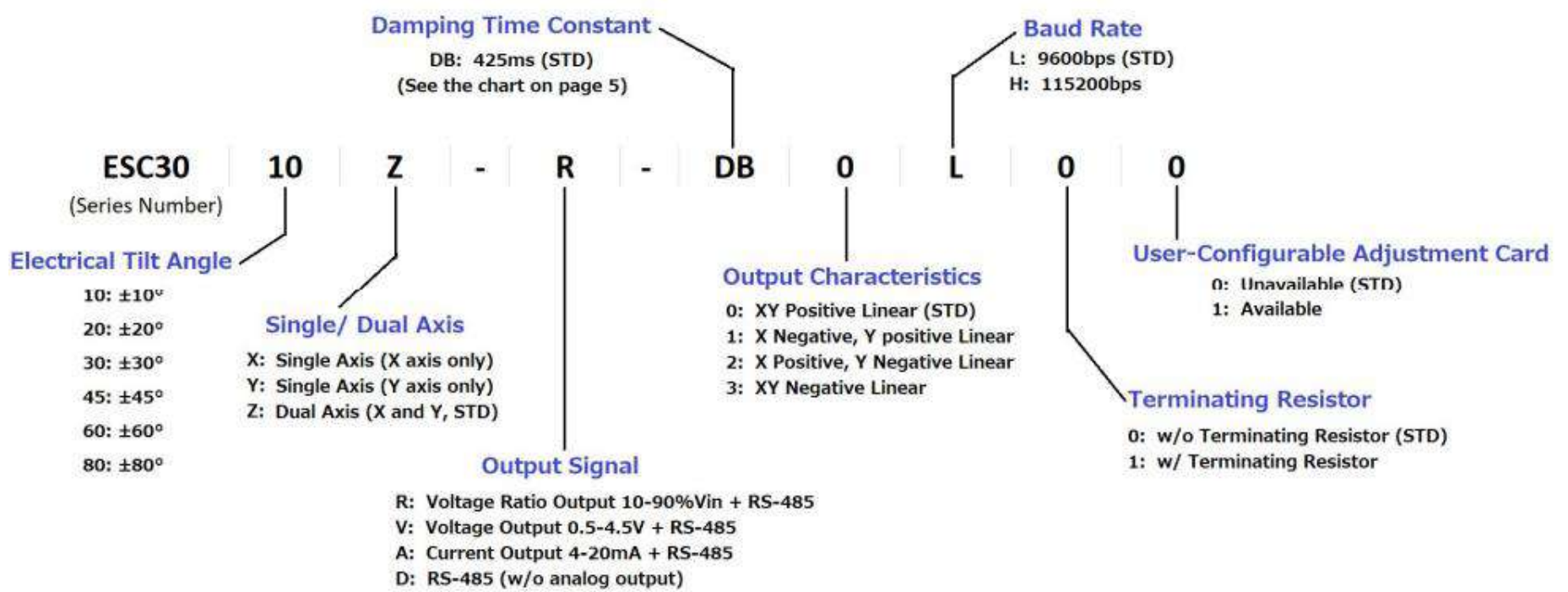

## Handling Instruction

- This product can not be used for measurement of resistance value.
- This product may be influenced by an external magnetic field.
- Use this sensor in an environment protected from ESD.